

# SANITARY LINE REPLACEMENT

TYPICAL SLAB-ON-GRADE CUT REPAIR DETAIL

CODE: FBC 2023, 8th EDITION

ADDRESS: \_\_\_\_\_

OWNER: \_\_\_\_\_ DATE: \_\_\_\_\_

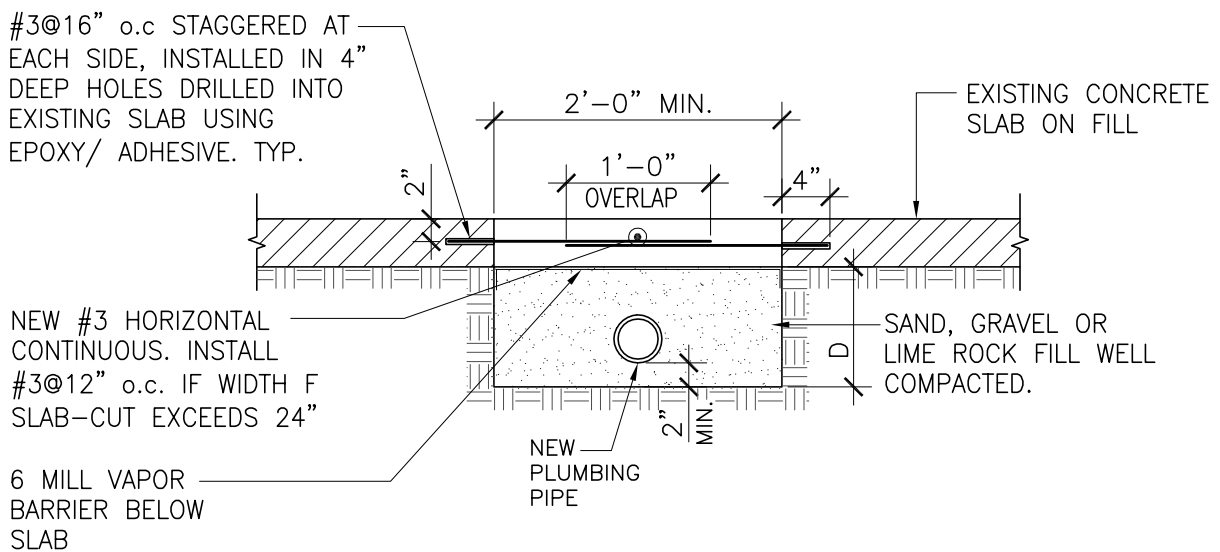

## SLAB-CUT REPAIR DETAIL

SCALE 3/4" = 1'-0"

1. CONCRETE COMPRESSIVE STRENGTH  $F'_c = 3000$  PSI.
2. REINFORCING: TO BE DEFORMED BARS CONFORMING ASTM A615, GRADE 60.
3. CLEAN AND ROUGHEN THE CONTACT SURFACES AT EACH SIDE OF SLAB CUT AND PROVIDE BONDING AGENT PRIOR TO POURING.
4. "D": DEPTH OF TRENCH AS NEEDED TO ACHIEVE REQUIRED PIPER SLOPE.

## TERMITE PROTECTION

PROVIDE SOIL TREATMENT PROTECTION AGAINST SUBTERRANEAN TERMITES FOR ALL SLAB CUTS IN COMPLIANCE W/ FBC SECTION 1816. A CERTIFICATE OF COMPLIANCE SHALL BE ISSUED TO THE BUILDING DEPARTMENT BY A LICENSED PEST CONTROL COMPANY THAT CONTAINS THE FOLLOWING STATEMENT: "THE BUILDING HAS RECEIVED TREATMENT FOR THE PREVENTION OF SUBTERRANEAN TERMITES. TREATMENT IS ACCORDANCE WITH RULES AND LAWS ESTABLISHED BY THE FLORIDA DEPARTMENT OF AGRICULTURE AND CONSUMER SERVICES."